



GM 1.7D (ISUZU) / Synchronous Drive / Tensioner Info.

GATES REFERENCE:	5563XS & related kits.	
MAKE:	CHEVROLET / OPEL / VAUXHALL.	
MODEL:	Astra, Combo, Corsa, Cruze, Meriva, Mokka, Trax, Vita, Zafira.	
MOTOR:	1.7CDTI, 1.7D, 1.7DI, 1.7DTI.	
MOTOR CODE:	A17DT, A17DTC, A17DTE, A17DTF, A17DTJ, A17DTL, A17DTR, A17DTS, Y17DT, Y17DTL, Z17DT, Z17DTH, Z17DTJ, Z17DTR.	

This Technical Bulletin replaces Technical Bulletin N° 009.

Explanation:

Apart from the fact that two different tensioners have been installed over the life of the engine, the installation procedure and tension setting is very critical on this application.

Tensioner difference:

Up to engine nr 328703 (last 6 digits) the initial tensioner was installed as shown in Fig. 1. From engine nr 328704 this tensioner was replaced by a new version (Fig. 2). For the 1.7 D engines, OE does not allow to use the old tensioner version anymore.

That is why our kits only contain the new tensioner. (Fig. 2)











Fig. 1 OE 5636724



Fig. 2 OE 5636739



Main differences in composition and application:

			+	
K015563XS	5563XS			I-> eng nr 328704
K025563XS	5563XS			ALL engines
K035563XS	5563XS			->I eng nr 328703

As the initial tensioner base plate was fitted under a leg of the engine support bracket (Fig. 3), K015563XS can only be used from engine nr 328704 on.

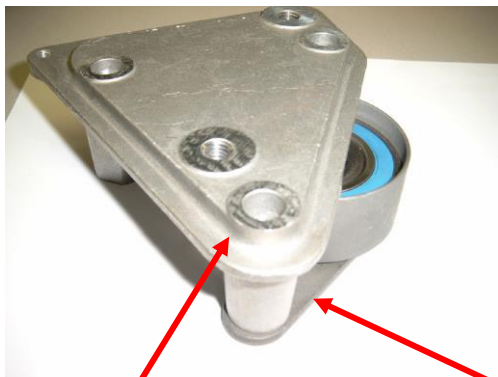

Fig. 3

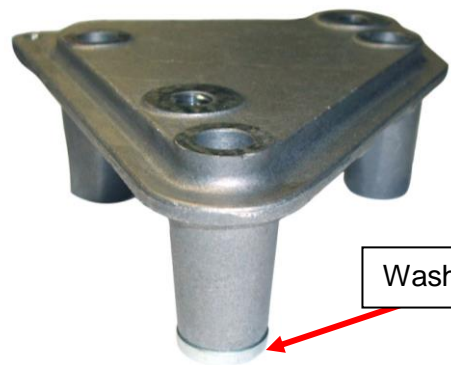

Fig. 4

Engine support bracket	Base plate initial tensioner
------------------------	------------------------------

K025563XS is supplied with a washer to compensate the lost thickness of the base plate under the shorter leg of the early engine support bracket as in Fig. 4, and contains a stud which is needed to hook the new tensioner spring on (Fig. 5). This K02 can always be used: up to engine nr 328703, using the washer and the stud; and from engine nr 328704 without the washer and the stud.

K035563XS is supplied with the new OE engine support bracket, with 3 legs of the same length. This kit can be used up to engine nr 328703.





Installation / Tensioning:

This engine is VERY sensitive to wrong tension. Because of this, the installation / tensioning procedure must be followed precisely to avoid an idler failure.

Important – before start tensioning the belt:

The engine must be at ambient temperature.

Put the engine at Top Dead Centre (TDC).

Lock the camshaft pulley (M6 bolt at position 8 o'clock position) and the injection pump pulley (M8 bolt at 5 o'clock position).

Engine has to be supported before the engine support bracket is taken away.

A) Engines with the initial tensioner type (Fig. 1) installed:

- 1) Remove the used tensioner, spring, idler and belt.
- 2) Install the new idler and bolt.
- 3) Insert and torque (18.6 Nm) the stud at the right hand side of the injection pump pulley (Fig. 5).

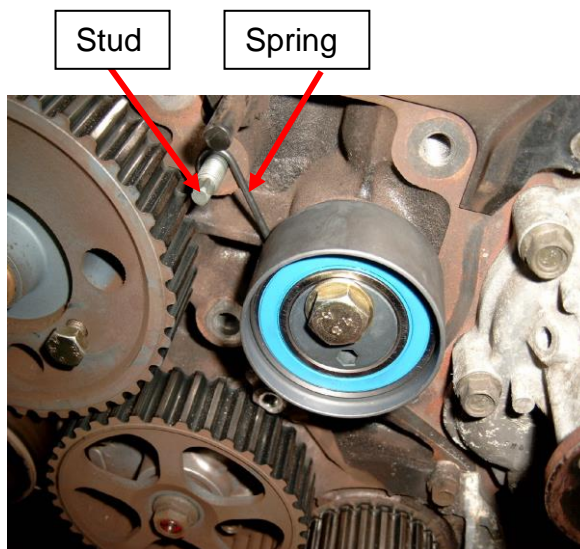

Fig. 5

- 4) Install the new coil spring tensioner (spring over stud, bolt hand tight); make sure tensioner is sitting perfectly against engine block. If not, the spring could end up between the tensioner and the engine block, creating a serious tensioner misalignment (see Fig. 6).
- 5) Rotate the tensioner anticlockwise (Allen key) till the Allen key hole is in +/- 5 o'clock position.
- 6) Tighten the bolt.





- 7) Install the new belt. The belt has to be taut on the left hand side (non-tensioner side) of the engine.
- 8) Loosen the tensioner bolt, allow the tensioner to apply tension, torque the tensioner bolt (49 Nm) **while holding the tensioner in place with the Allen key***.
- 9) Remove the camshaft and the injection pump locking bolts.
- 10) Rotate the engine (as prescribed by the manufacturer) via the crankshaft, check TDC; loosen the tensioner bolt, torque the tensioner bolt (49 Nm) **while holding the tensioner in place with Allen key****.
- 11) K025563XS: stick the washer (Fig. 4) on the bottom engine support leg (using fixing glue), in order to avoid losing the washer when loosening the support bracket bolt later.
K035563XS: install new bracket.
- 12) Re-install all other removed parts.

Spring trapped behind tensioner

Serious misalignment

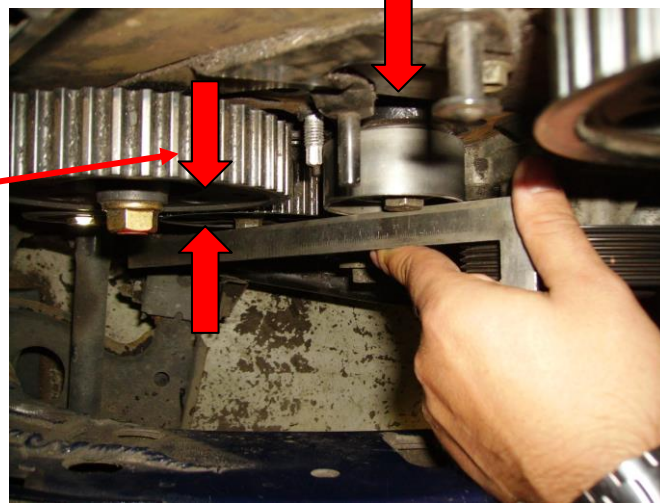

Fig. 6

B) Engines with a coil spring tensioner (Fig. 2) installed

NOTE: the installer does not need the stud and the washer for this version

- 1) Remove the old tensioner, spring, idler and belt.
- 2) Install the new idler and bolt.
- 3) Install the new coil spring tensioner (spring over stud, bolt hand tight); make sure the tensioner is sitting perfectly against the engine block. If not, the spring could end up between the tensioner and the engine block, creating a serious tensioner misalignment (see Fig. 6).
- 4) Rotate the tensioner anticlockwise (Allen key) till the Allen key hole is in +/- 5 o'clock position.
- 5) Tighten the bolt.
- 6) Install the new belt. Belt has to be taut on the left hand side (non-tensioner side) of the engine.



- 7) Loosen the tensioner bolt, allow the tensioner to apply tension, torque the tensioner bolt (49 Nm) **while holding the tensioner in place with the Allen key***.
- 8) Remove the camshaft and injection pump locking bolts.
- 9) Rotate the engine (as prescribed by the manufacturer) via the crankshaft, check TDC; loosen the tensioner bolt, torque the tensioner bolt (49 Nm) **while keeping the tensioner in place with the Allen key****.
- 10) Re-install all other removed parts.

Important – during the procedure:

* If the tensioner is moving even a little during the tightening of the bolt, this change in position will be translated in an exponential change of belt tension.

** After completing step 10 of the installation in procedure A), or step 9 in procedure B), it is highly recommended to check the tension in span **T**, (see drive system layout below - Fig. 7) using Gates Sonic Tension Tester STT-1.

Enter code 3618 in the STT-1 (ensure chip version 006 is installed) then measure in the normal way. If the tension is too high then the tensioner should be completely released and tensioning procedure repeated until the green light is obtained.

If the tension is too low then it will be necessary to assist the tensioner spring with the Allen key; until the green light is obtained.

*** Under **no other** circumstances should one assist the tensioner.

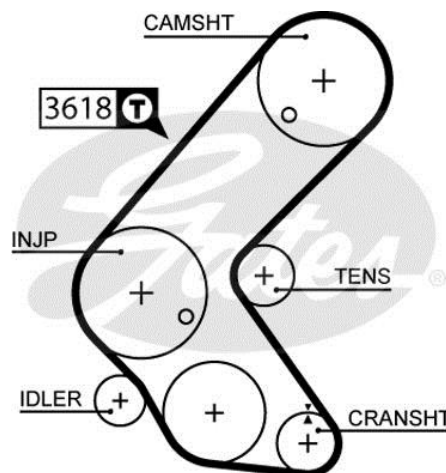

Fig. 7

Failure to observe this procedure could result in the belt tension being too high, leading to an overload on the guide pulley, between the oil pump and injection pump.



If the idler is of the old hollow type, this will usually causing the idler pulley to collapse (Fig. 8) and leading to severe engine damage.



Fig. 8

If the idler is of the new solid type (Fig. 9), the overload will cause belt damage, possibly leading to engine failure.



Fig. 9

Our kits contain the new solid idler from code date 201F onwards

GENERAL TIPS

- ENGINE HAS TO BE AT AMBIENT TEMPERATURE BEFORE START TENSIONING.
- NEVER RE-INSTALL A USED BELT
- DO NOT CRIMP THE BELT
- KEEP PRODUCT IN ITS PROTECTIVE PACKAGING UNTIL INSTALLATION
- FOLLOW MANUFACTURER'S INSTALLATION RECOMMENDATIONS

visit our web catalogue: <http://www.gatesautocat.com>

