



NUMBER 023

18/08/2008

PSA 1.8, 2.0 16V / Synchronous Drive / Tensioner Info.

GATES REFERENCE:	K025468XS & K035468XS.	
MAKE:	CITROEN / FIAT / LANCIA / PEUGEOT.	
MODEL:	306, 406, 605, 806, Evasion, Synergie, Ulysse, Xantia, XM, Xsara, Zeta, ZX.	
MOTOR:	1.8 16V, 2.0 16V.	
MOTOR CODE:	RFV, RFY, XU7JP4, XU10J4R, XU10J4RS.	

PowerGrip® Kit K025468XS is mainly for the PSA **2.0** 16V engines with manual tensioner. This kit contains the manual tensioner (OE ref. 082935, 9622574480. Gates ref. is T41258 (Fig. 1).

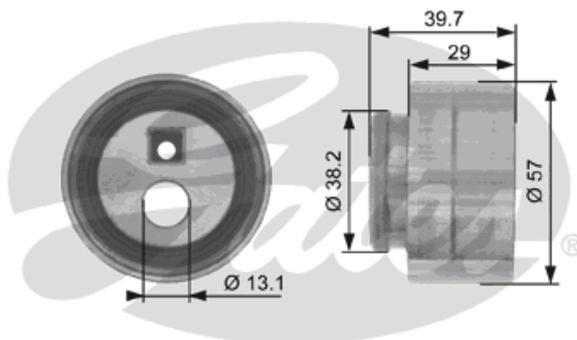

Fig. 1 Manual tensioner T41258 (K025468XS)

PowerGrip® Kit K035468XS is only for PSA **1.8** 16V engines. It includes an automatic tensioner (OE ref. 082969, 9635336880. Gates ref. is T43050. (Fig. 2) This automatic tensioner is an upgrade to the initially installed manual tensioner. This replacement is recommended and also applied by Peugeot/Citroen. The manual tensioner should no longer be used on the 1.8 16V applications on which our catalogue prescribes kit K035468XS.

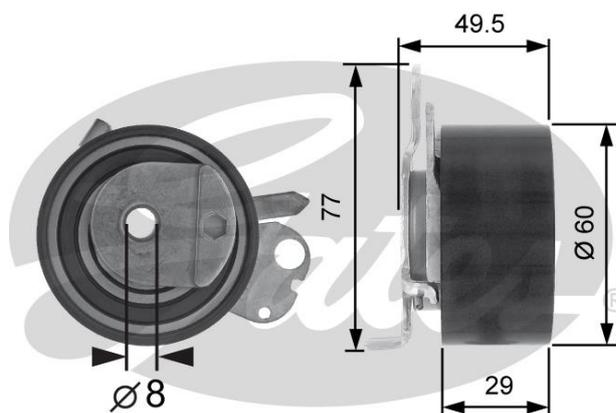

Fig. 2 Automatic tensioner T43050 (K035468XS)



For detailed application information, please check our web catalogue. We upgraded the drive layout on the kit and belt box-label: for the 2.0 16V engine, the idler position is corrected in the drive drawing. (Fig. 3) The tension on this 2.0 16V engine has to be checked (with Gates STT-1) between the right camshaft pulley and the idler (enter 5468XS-2).

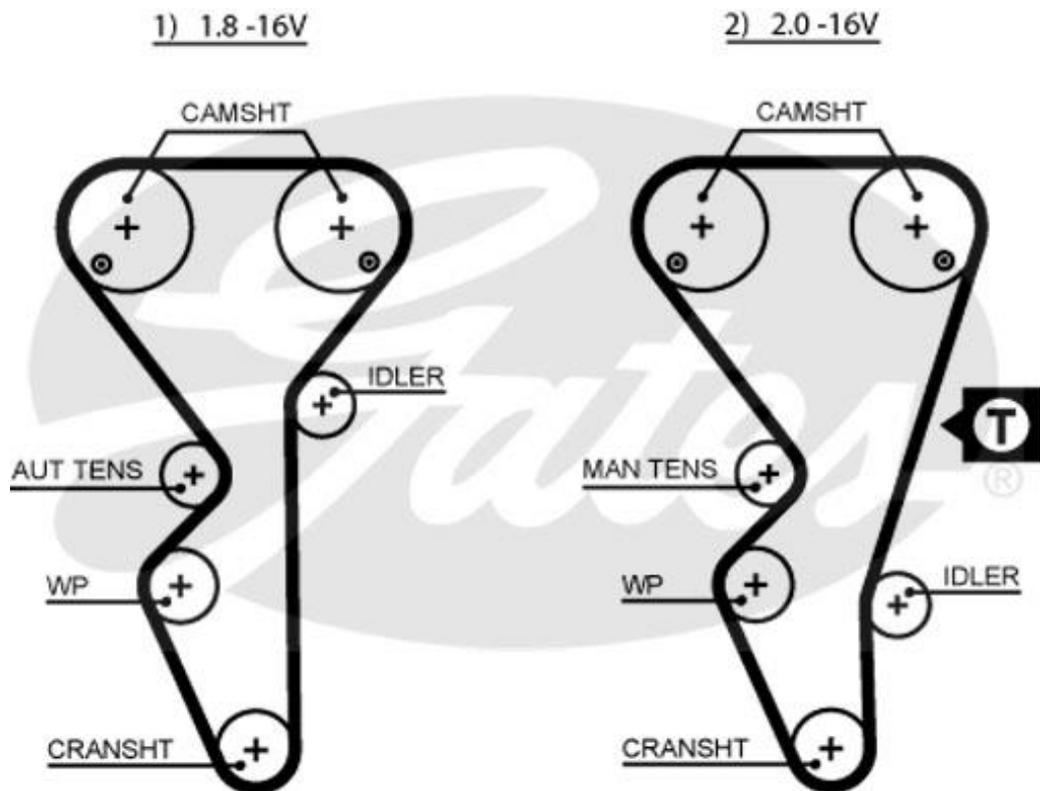

Fig. 3

visit our web catalogue : <http://www.gatesautocat.com>